

注：本册中的设备及技术参数若有变更，恕不另行通知。
以本公司改进后实际产品为准，本印刷品的最终解释权归本公司所有。



坚亮机械科技（东莞）有限公司

Jianliang Machinery Technology (Dongguan) Co., LTD.

地址ADD：广东省东莞市中堂镇东向村工业路31号

电话TEL：0769-81163299

手机号码：13928927581

http//: www.dgjlzj.com



坚亮机械

JIAN LIANG MACHINERY

制砖设备一体化专业制造商
INTEGRATED MANUFACTURERS OF BLOCK MAKING EQUIPMENT

► 砌块成型机 静压制砖机
自动码砖机 ► 自动打带机



以人为本 以诚兴企

目录 CONTENTS

公司简介	01
Company Profile	01
QT15-15型全自动混凝土砌块成型机	03
QT15-15 Fully Automatic Concrete Block Making Machine	03
QT10-15型全自动混凝土砌块成型机	05
QT10-15 Automatic Concrete Block Making Machine	05
QT6-15型全自动混凝土砌块成型机	07
QT6-15 Fully Automatic Concrete Block Making Machine	07
JL600/800/1000/1500型全自动单向静压制砖机	09
JL600/800/000/1500 Fully Automatic Single Direction Compression Brick Machine	09
JL800/1000/1500型全自动双向静压制砖机	11
JL800/1000/1500 Fully Double Direction Compression Brick Machine	11
JL- MD 1200自动低位码砖机	13
JL- MD 1200 Automatic Low-level Brick Machine	13
JL-1200型自留孔高位码垛系统	15
JL-1200 Automatic High Piling System	15
上旋打带机	17
Rotary Tying Machine	17
下旋打带机	18
Under-Spinning Winding Machine	18
立轴行星式搅拌机	19
Vertical Axis Planetary Mixer	19
JS系列卧式搅拌机	21
JS series horizontal mixer	21
LSY 型系列螺旋输送机 / PLD系列 混凝土配料机	22
Lsy Series Horizontal Mixer / PLD Series Concrete Batching Machine	22
砖机托板	23
Brick Machine Pallet	23
GBJ自动供板机	24
GBJ Automatic Board Supply Machine	24
全自动悬臂缠绕覆膜包装机	25
Fully Automatic Cantilever Wrapping and Shrink Packaging Machine	25
自动送架机/自动叠板机	26
AUTOMATIC DELIVERY MACHINE/AUTOMATIC PALLETIZER	26
砌块砖机模具	27
Concrete Block Machine M	27
部分产品实样	28
Part of the product sample	28
砖的应用	29
Application of Bricks	29
客户工厂案例	30
Customer Factory Case	30
全自动砌块生产流程图	31
Automatic block production process flow chart	31
竖亮服务	32
Solid Bright Service	32

坚亮机械科技（东莞）有限公司



公司简介 COMPANY PROFILE

坚亮机械科技（东莞）有限公司是一家专业生产水泥砖机的生产厂家。主要生产的有水泥砖机、免托板砖机、环保砖机、高位码垛机、低位码垛机、上旋打带机、下旋打带机、自动穿剪打带机、叠板机、搅拌机、自动上板机、配料斗、水泥管模、水泥管自动投料机、沙石输送带等水泥砖机设备，同时公司可为用户提供砖机设备项目设计、工艺流程设计、标准和非标准产品设计及生产。

公司拥有自营进出口权，部分产品出口中东、东南亚、非洲、欧洲及美洲等国家和其它地区，产品畅销全国各地。

坚亮机械公司拥有一支研发实力强劲的优秀队伍，拥有自主知识产权，先后研发了国际领先、国内独家拥有的几款混凝土砌块成型机，并得到了国内外客户的充分肯定，出口订单逐年稳步增加，国内销量增幅显著。

坚亮机械生产的QT系列混凝土砌块成型机经过十多年的不断改进和完善，已经非常稳定，产品规格齐全，性能可靠，质量优异，服务周到及时，广泛满足用户的不同要求。

我们秉承“质量第一、性能第一、服务第一”的企业理念，充分为用户和使用单位做好售前、售中、售后服务工作，为国内外客户提供理想的混凝土砌块成型设备。

Dongguan Jianliang Machinery Technology Co., Ltd. is a professional manufacturer of cement brick machines. The main products are cement brick machine, no pallet brick machine, environmental brick machine, high-position palletizing machine, low-position palletizing machine, upper rotating belt machine, lower rotating belt machine, automatic piercing and cutting belt machine, laminating machine, mixer automatic board feeding machine, batching hopper, cement pipe mold, cement pipe automatic feeding machine, sand and stone conveyor belt and other cement brick machine equipment. At the same, the company can provide users with brick machine equipment project design, process flow design, standard and non-standard product design and production.

The company has its own import and export rights, and some products are exported to the Middle East, Southeast Asia, Africa, Europe and America and other, and the products are selling well all over the country.

Jianliang Machinery Co., Ltd. has a strong R&D team with independent intellectual property rights, and has successively developed several concrete block machines that are internationally leading and domestically unique, which have been fully affirmed by domestic and foreign customers, and the export orders have increased steadily year by year, and the sales have increased significantly.

The QT series concrete block molding machine produced by Jianliang Machinery has been continuously improved and perfected for more than ten years, and it is very stable with a full range of product specifications, reliable performance, excellent quality, thoughtful and timely service, and it widely meets the different requirements of users.

We adhere to the corporate philosophy of "Quality First, Performance First, Service First", fully providing pre-sale, in-sale, and after-sale service for and units, and providing ideal concrete block molding equipment for domestic and foreign customers.

QT15-15型

全自动混凝土砌块成型机

FULL-AUTOMATIC CONCRETE BLOCK MAKING MACHINE

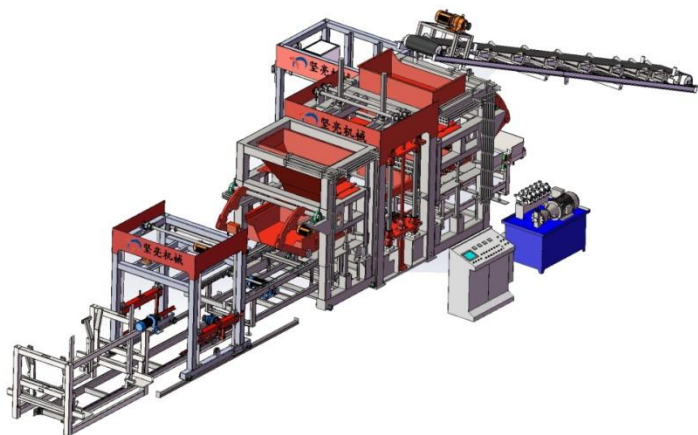

QT15-15参数表

QT12-15参数表

主要技术参数 TECHNICAL SPECIFICATIONS	
振动频率 Vibration frequency	3800-4500 (Times/Sub)
整机重量 Total weight	13.5 (T)
外形规格 Machine size	11000*2500*3100 (mm)
装机容量 Total power	87 (kw)
成型周期 Cycle Time	15-23 (s)
额定压力 Rated pressure	31.5mpa
激振力 Vibration force	220KN
托板规格 Pallet size	1280*1150*30 (mm)
成型方式 Vibration type	振动加压成型 /hydraulic vibration
叠板机装机容量 stacking machine power	5.5KW

主要技术参数 TECHNICAL SPECIFICATIONS	
振动频率 Vibration frequency	3800-4500 (Times/Sub)
整机重量 Total weight	12.5 (T)
外形规格 Machine size	9650*2200*3050 (mm)
装机容量 Total power	80 (kw)
成型周期 Cycle Time	15-23 (s)
额定压力 Rated pressure	25mpa
激振力 Vibration force	75-120KN
托板规格 Pallet size	1100*1100*30 (mm)
成型方式 Vibration type	振动加压成型 /hydraulic vibration
叠板机装机容量 stacking machine power	5.5KW

产量表 YIELD TABLE			
名称 Name	规格 size (mm)	块/模 PCS/Mould	块/8小时 PCS/8 Hours
空心砖 Hollow Block	390*190*190	15	22500-30000
多孔砖 Porous Block	240*115*90	40	60000-80000
标砖 Solid Brick	240*115*51	80	126000-168000
彩色地磚 Holland Brick	200*100*60	46	60060-76230

产量表 YIELD TABLE			
名称 Name	规格 size (mm)	块/模 PCS/Mould	块/8小时 PCS/8 Hours
空心砖 Hollow Block	390*190*190	12	17280-23040
多孔砖 Porous Block	240*115*90	35	50400-67200
标砖 Solid Brick	240*115*51	68	86400-115200
彩色地磚 Holland Brick	200*100*60	36	55296-69120

所有数据及图片仅供参考
 All data and pictures are for reference only.

技术特点

- 进口高效能液压比例系统纯正部件(更高效、节能)
- 进口智能PLC触摸屏及纯正电气原件(自动化程度高、操作更简便)
- 破拱式快速布料装置(对多孔砖布料特别有利、更均匀)
- 扩展式高效振动技术(产品成型时间更短、密实度更高)
- 高温热处理特殊工艺(模具更耐磨更坚固)

生产原料

采用碎石粉、沙子、石子、水泥、可大量添加粉煤灰、炉渣、钢渣、煤矸石、陶粒、珍珠岩等多种工业废料。一机多用漏斗更换模具可生产各种规格砌块:

- ① 多孔砖及空心砌块等;
- ② 陶粒保温砌块;
- ③ 复合保温混凝土砌块;

以上产品具有良好的保温隔热性能,能满足国家新的节能政策要求。

Technical characteristic:

-Imported high-effect hydraulic proportion system pure component(more efficient and energy conservation)
 Imported intelligence PLC touch screen and pure electrical element(high automation and easy to operate)
 Arch breaking type rapid feeding device(better feeding for multi-hole brick with better uniformity).Extend type high efficient vibrotechnique(Forming production faster and with higher compactedness)
 High-heat treatment special technology(to make the mould more durable and more firm)

Raw material:

Using small rock,sand,stones,cement,can be heavy addition with fly-ash,slag,coal gangue,ceramsite,pearlite and etc many type or industrial waste.
 On maching with multiple uses,by changing mould it can produce all type of standard building blocks.

- ① Multi-holes block and hollow block
- ② Ceramsite heat preservation block
- ③ Composite heat preservation concrete block

The above production come with good heat preservation performance,and satisfy the nation-nalnew energy conservation policydemand.

地基图 GROUNDWORK DRAWING

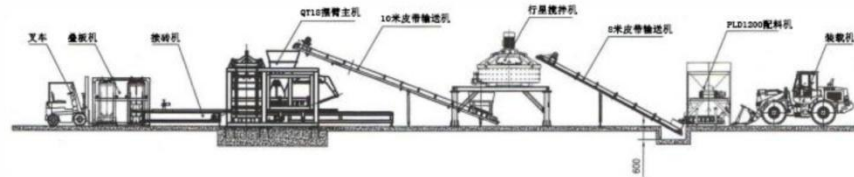

QT10-15 型

全自动混凝土砌块成型机

FULL-AUTOMATIC CONCRETE BLOCK MAKING MACHINE

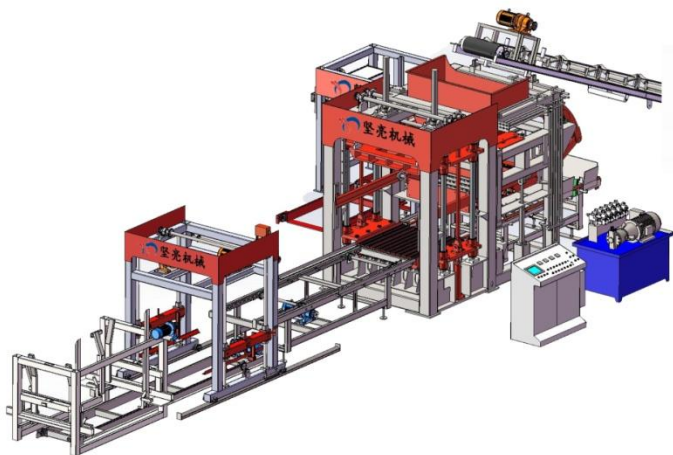

QT10-15参数表

QT8-15参数表

主要技术参数 TECHNICAL SPECIFICATIONS	
振动频率 Vibration frequency	3800-4500 (Times/Sub)
整机重量 Total weight	12 (T)
外形规格 Machine size	8760*2200*3020 (mm)
装机容量 Total power	77 (kw)
成型周期 Cycle Time	15-23 (s)
额定压力 Rated pressure	31.5mpa
激振力 Vibration force	105KN
托板规格 Pallet size	1100*880*30 (mm)
成型方式 Vibration type	振动加压成型 /hydraulic vibration
叠板机装机容量 stacking machine power	4.5KW

主要技术参数 TECHNICAL SPECIFICATIONS	
振动频率 Vibration frequency	3800-4500 (Times/Sub)
整机重量 Total weight	10.5 (T)
外形规格 Machine size	8760*2050*3020 (mm)
装机容量 Total power	55 (kw)
成型周期 Cycle Time	13-20 (s)
额定压力 Rated pressure	31.5mpa
激振力 Vibration force	95KN
托板规格 Pallet size	970*880*30 (mm)
成型方式 Vibration type	振动加压成型 /hydraulic vibration
叠板机装机容量 stacking machine power	4.5KW

产量表 YIELD TABLE			
名称 Name	规格 size (mm)	块/模 PCS/Mould	块/8小时 PCS/8 Hours
空心砖 Hollow Block	390*190*190	10	14400-19200
多孔砖 Porous Block	240*115*90	24	34560-46080
标砖 Solid Brick	240*115*51	51	85000-100000
彩色地砖 Holland Brick	200*100*60	27	46800-59400

产量表 YIELD TABLE			
名称 Name	规格 size (mm)	块/模 PCS/Mould	块/8小时 PCS/8 Hours
空心砖 Hollow Block	390*190*190	8	11520-15360
多孔砖 Porous Block	240*115*90	21	30240-40320
标砖 Solid Brick	240*115*51	45	67500-90000
彩色地砖 Holland Brick	200*100*60	24	40320-53760

注：以上产量表为理论计算值，成型周期，主产量与原材料、产品类型有关。
 All data and pictures are for reference only.

技术特点

- 进口高效能液压比例系统纯正部件(更高效、节能)
- 进口智能PLC触摸屏及纯正电气原件(自动化程度高、操作更简便)
- 破拱式快速布料装置(对多孔砖布料特别有利、更均匀)
- 扩展式高效振动技术(产品成型时间更短、密实度更高)
- 高温热处理特殊工艺(模具更耐磨更坚固)

生产原料

采用碎石粉、沙子、石子、水泥、可大量添加粉煤灰、炉渣、钢渣、煤矸石、陶粒、珍珠岩等多种工业废料。一机多用漏斗更换模具可生产各种规格砌块：

- ① 多孔砖及空心砌块等；
- ② 陶粒保温砌块；
- ③ 复合保温混凝土砌块；

以上产品具有良好的保温隔热性能，能满足国家新的节能政策要求。

Technical characteristic:

-Imported high-effect hydraulic proportion system pure component(more efficient and energy conservation)
 Imported intelligence PLC touch screen and pure electrical element(high automation and easy to operate)
 Arch breaking type rapid feeding device(better feeding for multi-hole brick with better uniformity).Extend type high efficient vibrotechnique(forming production faster and with higher compactedness)
 High-heat treatment special technology(to make the mould more durable and more firm)

Raw material:

Using small rock,sand,stones,cement,can be heavy addition with fly-ash,slag,coal gangue,ceramsite,pearlite and etc many type or industrial waste.
 On machining with multiple uses,by changing mould it can produce all type of standard building blocks.
 ① Multi-holes block and hollow block
 ② Ceramsite heat preservation block
 ③ Composite heat preservation concrete block
 The above production come with good heat preservation performance,and satisfy the nation-nalnew energy conservation policydemand.

地基图 GROUNDWORK DRAWING

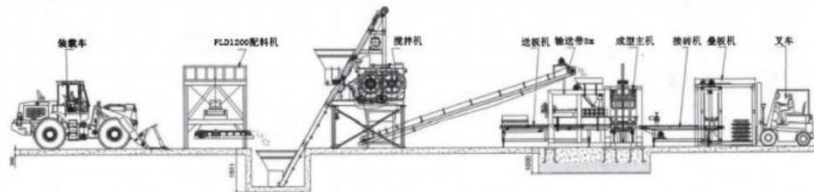

QT6-15 型

全自动混凝土砌块成型机

FULL-AUTOMATIC CONCRETE BLOCK MAKING MACHINE

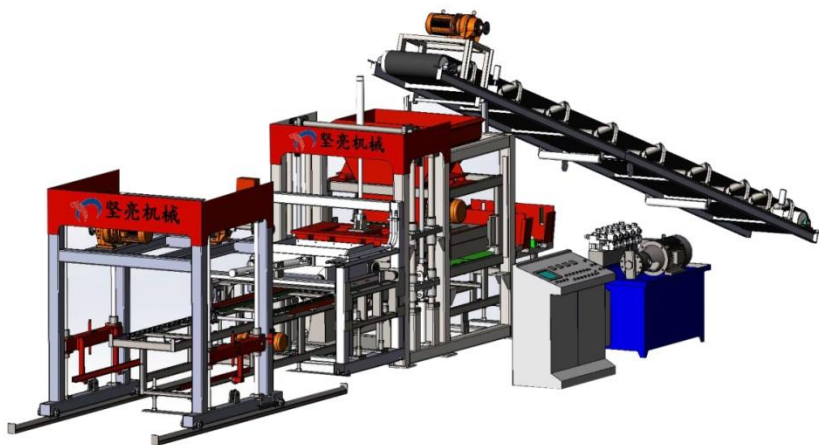

QT6-15参数表

主要技术参数 TECHNICAL SPECIFICATIONS	
振动频率 Vibration frequency	3800-4500 (Times/Sub)
整机重量 Total weight	8 (T)
外形规格 Machine size	7800*1800*3000 (mm)
装机容量 Total power	43 (kw)
成型周期 Cycle Time	12-20 (s)
额定压力 Rated pressure	31.5mpa
激振力 Vibration force	68KN
托板规格 Pallet size	850*680*30 (mm)
成型方式 Vibration type	振动加压成型 /hydraulic vibration
叠板机装机容量 stacking machine power	3.7KW

QT4-15参数表

主要技术参数 TECHNICAL SPECIFICATIONS	
振动频率 Vibration frequency	3800-4500 (Times/Sub)
整机重量 Total weight	6.8 (T)
外形规格 Machine size	6600*1800*2800 (mm)
装机容量 Total power	33 (kw)
成型周期 Cycle Time	12-18 (s)
额定压力 Rated pressure	25mpa
激振力 Vibration force	68KN
托板规格 Pallet size	850*550*30 (mm)
成型方式 Vibration type	振动加压成型 /hydraulic vibration
叠板机装机容量 stacking machine power	3.7KW

产量表 YIELD TABLE			
名称 Name	规格 size (mm)	块/模 PCS/Mould	块/8小时 PCS/8 Hours
空心砖 Hollow Block	390*190*190	6	8640-11520
多孔砖 Porous Block	240*115*90	15	21600-28800
标砖 Solid Brick	240*115*51	32-36	46080-61400
彩色地磚 Holland Brick	200*100*60	21-24	27300-34650

注：以上产量表为理论计算值，成型周期，主产量与原材料、产品类型有关。
 All data and pictures are for reference only.

产量表 YIELD TABLE			
名称 Name	规格 size (mm)	块/模 PCS/Mould	块/8小时 PCS/8 Hours
空心砖 Hollow Block	390*190*190	4	5670-7680
多孔砖 Porous Block	240*115*90	14	20160-26880
标砖 Solid Brick	240*115*51	26-28	37440-49920
彩色地磚 Holland Brick	200*100*60	14-16	18200-23100

注：以上产量表为理论计算值，成型周期，主产量与原材料、产品类型有关。

技术特点

- 进口高效能液压比例系统纯正部件(更高效、节能)
- 进口智能PLC触摸屏及纯正电气原件(自动化程度高、操作更简便)
- 破拱式快速布料装置(对多孔砖布料特别有利、更均匀)
- 扩展式高效振动技术(产品成型时间更短、密实度更高)
- 高温热处理特殊工艺(模具更耐磨更坚固)

生产原料

采用碎石粉、沙子、石子、水泥、可大量添加粉煤灰、炉渣、钢渣、煤矸石、陶粒、珍珠岩等多种工业废料。一机多用漏斗更换模具可生产各种规格砌块：

- ① 多孔砖及空心砌块等；
- ② 陶粒保温砌块；
- ③ 复合保温混凝土砌块；

以上产品具有良好的保温隔热性能，能满足国家新的节能政策要求。

Technical characteristic:

-Imported high-effect hydraulic proportion system pure component (more efficient and energy conservation)
 Imported intelligence PLC touch screen and pure electrical element (high automation and easy to operate)
 Arch breaking type rapid feeding device (better feeding for multi-hole brick with better uniformity).
 Extend type high efficient vibro technique (Forming production faster and with higher compactedness)
 High-heat treatment special technology (to make the mould more durable and more firm)

Raw material:

Using small rock, sand, stones, cement, can be heavy addition with fly-ash, slag, coal gangue, ceramsite, pearlite and etc many type or industrial waste.
 On machining with multiple uses, by changing mould it can produce all type of standard building blocks.

- ① Multi-holes block and hollow block
- ② Ceramsite heat preservation block
- ③ Composite heat preservation concrete block

The above production come with good heat preservation performance, and satisfy the nation- new energy conservation policy demand.

地基图 GROUNDWORK DRAWING

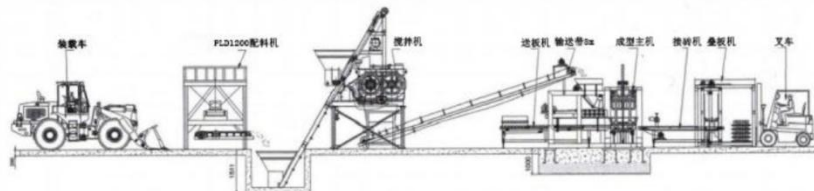

600/800/1000/1500型
全自动单向静压制砖机

AUTOMATIC ONE-WAY STATIC PRESSING BRICK MACHINE



低噪音

省人工

高密度

主要技术参数 TECHNICAL SPECIFICATIONS

项目 Project	600型单压	800型单压	1000型单压	1500型单压
最大压力 Maximum pressure	31.5Mpa	31.5Mpa	31.5Mpa	31.5Mpa
整机重量 Total weight	约23吨	约24吨	约29吨	约39吨
总功率 Total power	46.9KW	54.9KW	66.4KW	88.4KW
主油缸缸径 Cylinder diameter of main cylinder	φ450cm	φ500cm	φ600cm	φ720cm
成型周期 Cycle Time	16s-22s	17s-21s	17s-22s	18s-23s
成型面积 Forming area	850*700mm	1100*680mm	1100*850mm	1440*850mm
托板规格 Pallet size	950*750*20mm	1150*750*20mm	1150*900*20mm	1500*900*30mm

产量表 YIELD TABLE

名称及图片 Name and picture	规格尺寸 Dimension (mm) Size	成型周期 Cycle Time	600型单压 Cycle Time	800型单压 块模 PCS Mould	1000型单压 块模 PCS Mould	1500型单压 块模 PCS Mould
彩色地磚 Holland Brick	 200*100*60	18-22s	21	24	27	40
标准燕 Solid Brick	 240*115*51	18-22s	22	28	45	57
实心磚 Solid Brick	 170*80*80	18-22s	24	30	36	42

 ★所有数据及图片仅供参考。
 All data and pictures are for reference only.

B00/1000/1500型

全自动双向静压制砖机

AUTOMATIC TWO-WAY STATIC PRESSING BRICK MACHINE

主要技术参数 TECHNICAL SPECIFICATIONS

项目 Project	800型双压	1000型双压	1500型双压
最大压力 Maximum pressure	31.5Mpa	31.5Mpa	31.5Mpa
整机重量 Total weight	约22-25吨	约33吨	约43吨
总功率 Total power	58.2KW	105.4KW	108.2KW
主油缸缸径 Cylinder diameter of main cylinder	φ500cm	φ600cm	φ720cm
成型周期 Cycle Time	17s-22s	17s-21s	18s-23s
成型面积 Forming area	1100*680mm	1100*850mm	1440*850mm
托板规格 Pallet size	1200*750*20mm	1200*950*20mm	1500*950*30mm

低噪音

省人工

高密度



产量表 YIELD TABLE

名称及图片 Name and picture	规格尺寸 Dimension (mm) Size	成型周期 Cycle Time	800型单压 块/模 PCS/Mould	1000型单压 块/模 PCS/Mould	500型单压 块/模 PCS/Mould
彩色地砖 Holland Brick	 200*100*60	18-22s	24	27	40
标准砖	 240*115*51	18-22s	28	45	57
实心砖 Solid Brick	 170*80*80	18-22s	30	36	42



MD1200型

自动低位码砖机

AUTOMATIC BRICK MACHINA

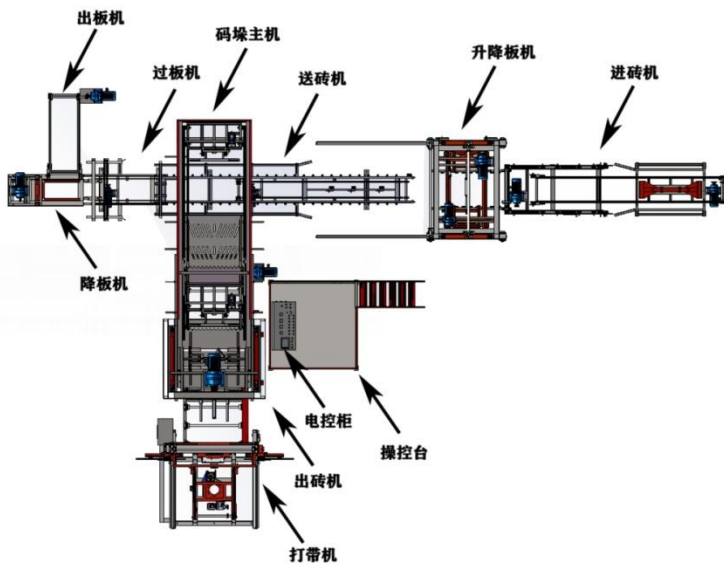
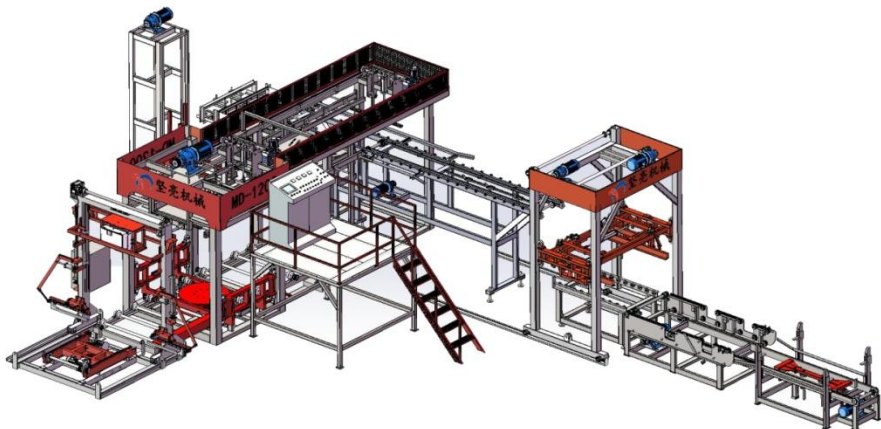

技术特点

本码垛生产线适用于简易型砌块生产线的干产品码垛，属于半自动码垛生产线，一般情况下独立设置于产品养护堆场附近，对于养护好的制品就地码垛，亦可串联于砌块生产线之中，实施在线码垛。本自动码垛系统可将不同型号砖机生产的不同规格的砌块进行 砖板分离，排块整理最后排成最大1200(mm)的方垛进行码放(标准实心砖一次码放高度最多可达12层)层出砖可选择进行缠绕膜打包，也可以用带机自动打带。配合叉车抱夹可不用托盘直接抱到场地码垛，堆放高度可放3垛。整套系统采用PLC+ 触摸屏控制，只需一人操作。每小时码砖量约210层可大大节约人工成本。

Equipment Introduction

This code-stacking production line is suitable for the dry product stacking of simple block production lines. It belongs to a semi-automatic code-ing production line. Under normal circumstances, it is set independently near the product curing yard. For well-cured products, it is stacked on the spot. It can also be connected in series with the block production line to implement online stacking. This automatic code-stacking system can separate different models of brick machines and produce different specifications of blocks for brick plate, and arrange the blocks to be finally arranged into a maximum of 1200 (mm) square stacks for stacking. The standard solid brick is stacked up to a maximum 12 layers at a time). After the brick is discharged, it can be wrapped with film packaging, or it can be automatically tied with a strapping machine. In with the forklift clamping, it can be directly clamped to the site stacking without a pallet, and the stacking height can be placed up to 3 stacks, entire system uses PLC touch screen control, which requires only one person to operate. The amount of bricks stacked per hour is about 210 layers, which can greatly labor costs.

主要技术参数 TECHNICAL SPECIFICATIONS

整机功率	35Kw (不含7.5Kw空压机) (实际运行功率14.2Kw)
码砖规格最大尺寸	长1200mm. 宽1200mm高1450mm
码垛周期	平均周期15秒
整机重量	11吨
砖型范围	同向排列的常规砖型均实用。(三角形砖外)
适用托板规格尺寸	4型机至15型机率

收砖砖型周期表 BRICK COLLECTTON TYEE CYCLE TABLE

品种	砖型规格	码垛尺寸规格1及速度	码垛尺寸规格2及速度	码垛尺寸规格3及速度
标砖	240*50*115	长960*宽960的常规层, 每层76块, 留孔层52块, 每小时12432块, 每垛12层888块。	长1200宽1200的常规层, 每层120块, 留孔层96块, 每小时16992块, 每垛12层1416块。	
面砖	100*200*60	长950*宽950的常规层, 每层95块, 留孔层65块, 每小时19950块, 每垛12层1110块。	长1000宽1000的常规层, 每层50块, 留孔层35块, 每小时10500块, 每垛22层1085块。	长1200*宽1200的常规层, 每层120块, 留孔层96块, 每小时25200块, 每垛22层1416块。
砌块砖	390*190*190	长800*宽800的常规层, 每层8块, 留孔层6块, 每小时1680块, 每垛7层54块。	长1200宽1200的常规层, 每层18块, 留孔层12块, 每小时3780块, 每垛7层120块。	
配砖	190*50*90	长800*宽800的常规层, 每层32块, 留孔层20块, 每小时6720块, 每垛22层692块。	长1140宽1140的常规层, 每层132块, 留孔层96块, 每小时27720块, 每垛12层1548块。	

MB1200型

自留孔高位码垛系统

SELF RETENTION HOLE HIGH POSITION CODE SYSTEM

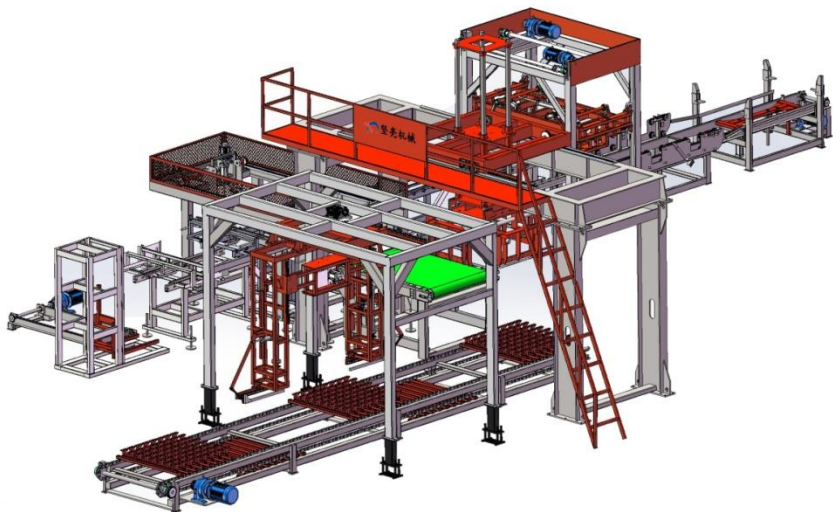

设备配置表

名称	型号	简介	数量	备注
进板升板系统	JL-1200	将叉车放入的砖垛输送至升板机然后将砖板一层一层提升到砖机分离机。	1	包含进板机、升板机
砖板分离系统	JL-1200	将升板机送入的砖板推送到位，通过一推将砖板进行分离，循环动作空板送到降板机。	1	包含推板机、一推砖机
分砖排列整理系统	JL-1200	根据不同托板的排列自动将制品排列整理成设定的尺寸数量。	1	包含皮带分离平台
分离留孔平台	JL-1200	根据不同规格制品不同砖垛尺寸自动分成相应的砖数，并按设置好的程序自动分离出砖孔位。	1	包含分离留孔平台
龙门式高位码垛系统	JL-1200	将整理好的砖垛交叉码放到出砖机上。	1	包含龙门式高位码垛机
出砖系统	JL-1200	将码好的砖垛通过输送链送至打包机及叉车拖砖位。	1	设备为无托盘四面穿带系统，标配长度8米。
降板、出板系统	JL-1200	将分离出的托板一张一张码放好后输送到叉车位。	1	包含降板机、出板机
翻板系统	JL-1200	将空托板翻转后以便后期生产用。	1	包含翻板机
液压系统	JL-1200	采用进口电液控制阀及流量压力双比例阀高效准确的控制设备油缸及马达动作。	1	
电控系统	JL-1200	通过PLC+触摸屏控制整套设备动作、人机参数调整、产量记录等。	1	可选配伺服系统
整套占地面积	~19000*10000(mm)设备最高高度5500mm		运行周期	13-15秒/层
总重量	~12000kg		总功率	45kw
码砖规格	1000*1000(mm)标准实心砖一层76块，一垛936块		最高码数尺寸	1400(mm)

设备简介

JL-1200型自留孔高位码垛系统是公司为了适应市场多元化发展需要潜心研发的拥有自主知识产权的专利产品。生产线适用于简易型砌块生产线的干产品码垛，属于半自动码垛生产线，一般情况下独立设置于产品养护堆场附近，对于养护好的制品就地码垛，亦可串联于砌块生产线之中，实施在线码。

本自动码垛系统可将不同型号砖机生产的不同品种、不同规格的砌块进行砖板分离、排块整理，最后组成一米左右的方垛进行交叉码垛，并可根据需要自动生成叉砖孔位。码高度最高可达1400mm,码完成后通过重型链式输送机整垛输出，可人工打包也可配套自动打包机。整套生产线上每个节点都有做预存位置节约叉车跑动时间。

整套系统采用PLC+触摸屏控制，配合光电感应+智能传感器，实现无人自动化运行，出现故障自动停机报警并显示故障位置，无需专业技术人员就可轻松排除故障。搭载远程控制系统+云数据设备生产厂家时时刻刻在办公室就可解决一切问题。设备运行采用电、气、液分别控制，互不干扰、动作连贯，约15s左右可码一层一个，班码砖量约15000块(标准砖)。

Equipment introduction

The XY-1200 type self-retention hole high-position palletizing system is a patent product with independent intellectual property developed by the company to meet the needs of market diversification. The production line is suitable for the dry product palletizing of simple block production lines. It belongs to a-automatic palletizing line. Generally, it is set independently near the product curing yard. For the cured products, it is palletized on the spot. It can be connected in series with the block production line to implement online palletizing.

This automatic palletizing system can separate different models of brick machines, produce different varieties, and specifications of blocks for brick separation, block arrangement, and finally form a square pile of about one meter for cross palletizing, and can automatically generate fork brick positions according to needs. The maximum palletizing height can reach 1400mm, and after completion, the whole pile is output through a heavy-duty chain conveyor, which can be packed or matched with an automatic packing machine. Each node on the whole production line has a pre-stored position to save forklift running time.

The whole system adopts PLC touch screen control, with photoelectric induction intelligent sensor, to achieve unmanned automatic operation. In case of failure, the machine will automatically stop and alarm and display the position. Professional technicians can easily eliminate the fault without the need for professional technicians.

The whole system is controlled by PLC touch screen, combined with photoelectric induction intelligent sensor, to achieve unmanned automatic operation, automatic shutdown case of fault, alarm and display the fault location, no professional technicians are needed to easily eliminate the fault. Equipped with remote control system cloud data equipment, the manufacturer can all problems at any time in the office. The equipment operation adopts separate control of electricity, gas and liquid, which does not interfere with each other and has smooth action, about 5s can code a layer, and the amount of brick coding per shift is about 15000 pieces (standard brick).

上旋打带机

TOP-SPIN BELT MACHINE

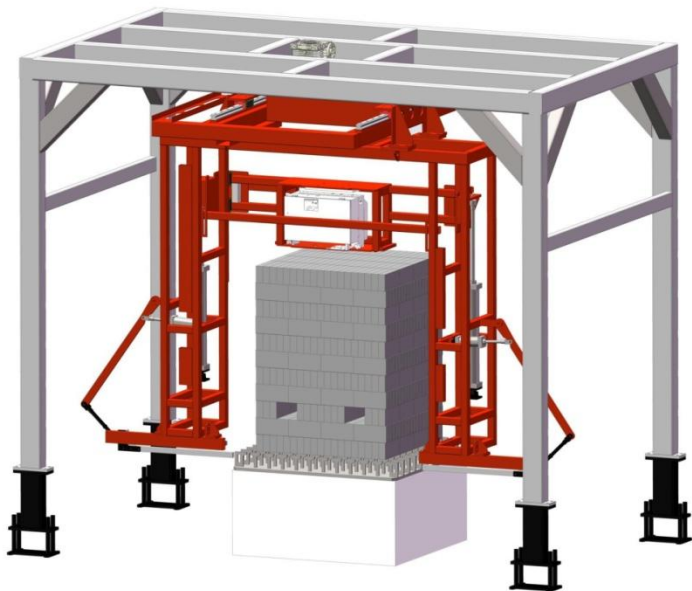

设备简介

- 全自动穿剑捆扎，运动机构伺服驱动：安全、可靠、平滑；
- 自研打包机芯，模块化设计，免工具维护，省心省钱；
- 高频摩擦焊接安全防护；

Equipment introduction

- Automatic sword-through bundling, servo-driven motion mechanism: safe, reliable, and smooth;
- Self-developed strapping machine, modular design, tool-free maintenance, worry-free and cost-effective;
- High-frequency friction welding for safe explosion prevention;

下旋打带机

UNDER-SPINNING WINDING MACHINE

一般参数		一般参数	
可编程控制器	汇川	定位设置	触摸屏数控示教任意设置 多程序模式编程可选
动力电源	3/N, PE, 380V	机芯移动速度	180 mm/sec
控制电压	24V DC	框架平台移动行程	2000mm
功率	5.4KW	框架平台移动速度	150mm/sec
机器重量	1400kg	打带位置误差	± 10mm
标准货物尺寸	1200(W)*1200(L)*1500(H)	打带速度	13"
输送线高度	600 ± 50mm		

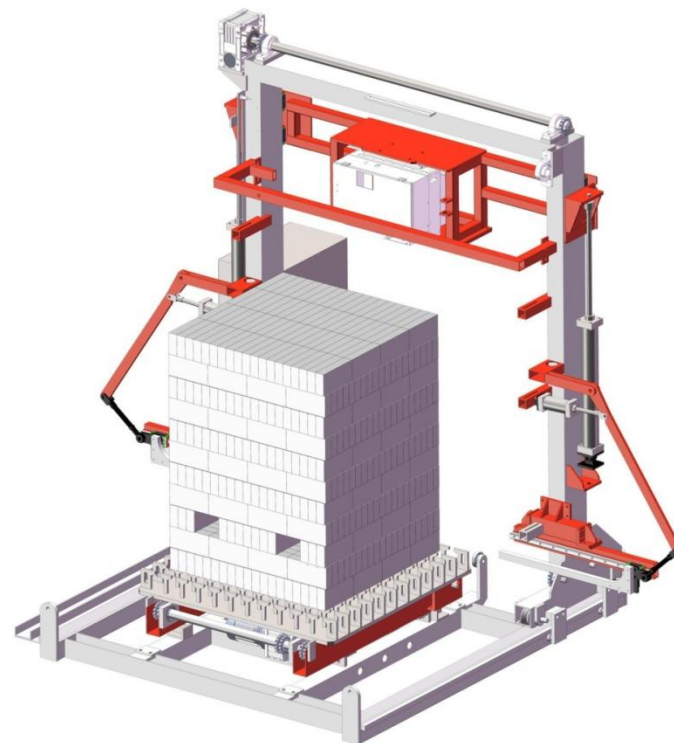

立轴行星式搅拌机

VERTICAL AXIS PLANETARY MIXER



设备简介

坚亮立轴行星式搅拌机采用德国技术，整机传动平稳、搅拌效率高、搅拌匀质性高(无死角搅拌)、独特的密封装置不存在漏浆漏料问题、耐用性强、内部清理干净方便(高压清洗装置选配项)、检修空间大。

传动装置：立轴行星式搅拌机的传动装置是采用欧洲先进技术的全油浴润滑方式的减速机机构，并且此项技术获得国家专利，整体结构的集成化、稳定性好。立轴行星式搅拌机的电机与减速机之间可以根据客户的需要选用不同的连接方式。

立轴行星式搅拌机的搅拌形式：立轴行星式搅拌机的搅拌形式多种多样，主要分为标准搅拌形式和差速搅拌形式来使用不同客户的物料搅拌要求，立轴行星式搅拌机的差速搅拌形式包含一组快速输出装置，并且搅拌工具可以根据要求来单独设计，目的是为了达到不同客户的不同物料搅拌需求。

Equipment introduction

The vertical planetary mixer adopts German technology, with stable transmission, high mixing efficiency, high mixing uniformity (no dead angle mixing), a unique device without leakage problems, strong durability, clean and convenient internal cleaning (high-pressure cleaning device is an optional item), and a large inspection space. Transmission device: transmission device of the vertical planetary mixer is a reducer with full oil bath lubrication, which adopts advanced European technology and has obtained a national patent. The overall structure has good and stability. The motor and reducer of the vertical planetary mixer can be connected in different ways according to the customer's needs. Mixing form of vertical planetary mixer: mixing form of vertical planetary mixer is diverse, mainly divided into standard mixing form and differential mixing form to meet the mixing requirements of different customers. The differential mixing form of vertical planetary mixer a set of fast output devices, and the mixing tools can be designed separately according to the requirements, aiming to meet the different mixing needs of different customers for different materials.

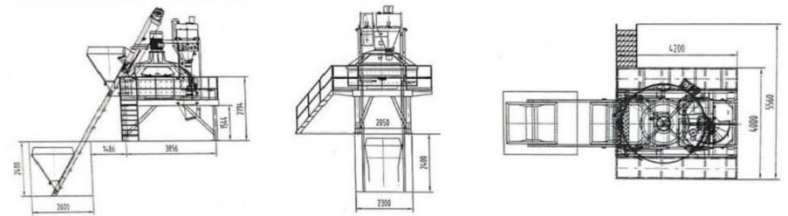

主要技术参数 TECHNICAL SPECIFICATIONS

型号/项目	CMP330	CMP500	CMP750	CMP1000	CMP1250	CMP1500	CMP2000
出料容量L	330	500	500	1000	1250	1500	1500
进料容量L	500	750	750	1500	1875	2250	2250
出料质量KG	800	1200	1200	2400	3000	3600	3600
搅拌额定功率KW	15	18.5	18.5	37	45	55	55
液压卸料功率KW				3	3	3	3
行星/主搅拌数	1/2	1/2	1/2	2/4	2/4	2/4	2/4
侧挂板	1	1	1	1	1	1	1
卸料刮板	1	1	1	1	1	1	1
搅拌机重量KG	2000	2400	2400	6200	6700	7700	7700
提升料斗功率KW	4	4	4	11	15	15	15
主机外形尺寸(mm)	870*1870*1855	2230*2080*1880	2230*2080*1880	2850*2602*2220	3060*2760*2305	3230*2902*2470	3625*3230*2630

JS 系列

卧式搅拌机

HORIZON MIXER

产品用途与特点

本机属双卧轴强制式混凝土搅拌机，适用于各类中、小型预制构件厂及砖机、公路、桥梁、水利、码头等工业及民用建设工程，可搅拌硬性混凝土、塑性混凝土、流动性混凝土、轻骨料混凝土和各种砂浆。除作为单机使用外，还可与PL1200型配料机组合成简易搅拌站，亦可作为HZS50搅拌站的配套主机。

Product use and features

This machine belongs to the double horizontal shaft forced concrete mixer, which is suitable for various medium and small prefabricated component factories brick machines, roads, bridges, water conservancy, wharfs and other industrial and civil construction projects. It can mix rigid concrete, plastic concrete, flowable concrete, light concrete and various mortars. In addition to being used as a single machine, it can also be combined with PL1200 type batching machine to form a simple mixing, and it can also be used as a supporting main engine of HZS50 mixing station.



●JS750型

●JS500型



主要技术参数TECHNICALSPECIFICATIONS

型号	JS500	JS750
进料容量 (L)	800	1200
出料容量 (L)	500	750
生产率 (m³/h)	20-30	30-35
骨料最大粒径 (卵石/碎石) mm	80/60	80/60
搅拌叶片	转速 (r/min)	30.4
	数量	2X7
搅拌电动机	型号	Y180M-4(B)
	功率 (KW)	18.5
卷扬电动机	型号	132M-4
	功率 (KW)	5.5
水泵	型号	WB-50-40-95
	功率 (KW)	1.1
电动推杆	型号	DT500-3011
	功率 (KW)	1.1
料斗提升速度 (m/min)	34	34
外形尺寸 (长X宽X高)	2520X2857X2145	3600X3400X2800
	4640X3600X3780	3600X3400X3800

LSY 型系列

螺旋输送机

STANDING MIXERZ1

产品用途与特点

LSY型系列螺旋输送机，是本公司参照我国从德国及意大利引进的同类产品设计开发的产品，是更新换代的优秀输送机机械产品。

主要用于砼搅拌站中输送水泥、粉煤灰等物料。新改良的LSY型系列产品的技术性，可靠性和实用性都有突破性的提高，产品的规格，型号已系列化。



●Z300型水泥称



●LSY 型系列(螺旋输送机)

Product use and features

The LSY series spiral conveyor is a product developed by our company based on the same type of products introduced from Germany and Italy. is an excellent conveying machinery product for updating and replacing.

PLD系列

混凝土配料机

Concrete batching machine



产品用途与特点

PLD系列混凝土配料机是一种与搅拌机配套使用的前台自动配料设备。它可根据用户设计的混凝土配比自动完成砂、石、水泥等3-6种物料(二级混凝土)的配料程序。

产品用途与特点

该系列产品是依照GB10172《混凝土搅拌站技术条件》中配料系统的技术标准设计的。该机采用电子称量，微机控制，数字显示，有宏遥控操作，具有称量准确、配料精度高、速度快、控制功能强等优点，操作容易到每次只需按一键。

项目	型号	PLD1200型二仓	PLD1800型二仓	PLD1800型三仓
称料斗容量		0.75m³	0.75m³	1m³
储料斗容量		2X4m³	2X6m³	3X6m³
生产率		30m³/h	30m³/h	30m³/h
配料精度		5%	5%	5%
最大称量值		700kg	1000kg	1000kg
可配骨料总数		1	2	3
上料高度		2500mm	3000mm	3000mm
功率		3X3KW	3X3KW	4X3KW
皮带带速		1: 17.5	1: 17.5	1: 17.5
外形尺寸 (长X宽X高)		5500X1200X2800mm	6000X1800X3000mm	8500X1800X3000mm

砖机托板

● 竹托板 PALLET



● PVC板 PVC PALLET



● BMT 纤维板 GMT FIBRE PALLET



● PVC板 PVC PALLET

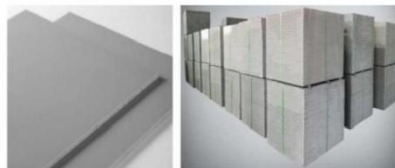

GBJ

自动供板机

AUTOMATIC PALLET FEEDER

主要功能

将生产现场不整齐的线板垛进行自动整齐并起，然后逐块自动送入送板机，进行砌块生产线循环使用。

技术特点

- 卸砖后的栈板可以比较随意的码放，节省卸砖收板时间
- 栈板垛高度可达1m，节省叉车转运次数，从而节约成本
- 栈板不在需要人工放入送板机，降低了劳动强度，同时节约机器操作人员2名

Main function

Automatically tidy and pile up the messy line board stacks on the production site, and then automatically send them into the board feeder one by one, cyclic use on the block production line.

Main function

- The stack boards after unloading bricks can be stacked relatively arbitrarily, saving time for unloading bricks and collecting boards
- The height of stack board pile can be up to 1m, saving the number of forklift transfer and thus saving cost
- The stack boards no longer need to be put into the machine manually, reducing the labor intensity and saving 2 operators for machine operation



省时间

省成本

省人工

主要技术参数 TECHNICAL SPECIFICATIONS

整机重量 Total weight	900(kg)
外型规格 Machine size	2800*2500*2500(mm)
装机容量 Total power	2.2(kw)
拼版空间 Cyce Time	1350(mm)
板垛最大高度 Vated pressure	1(m)
板垛最大重量 Vibration force	1500(kg)

全自动悬臂缠绕覆膜包装机

FULL AUTOMATIC CANTILEVER WINDING FILM WRAPPING MACHINE



设备简介

坚亮系列全自动悬臂缠绕覆膜包装机是悬臂缠绕包装机增加覆膜功能而成的集成一体式包装设备，能够完成缠绕包装和顶膜覆盖两种功能，可将形成五面封闭的防潮、防雨、防尘的包装体。完全实现无人化自动运行，效率高，包装成本低，广泛应用于食品饮料、化纤化工、冶金建材等行业，是提高自动化程度最佳设备。

设备构成

龙门悬臂骨架、回转支撑转动装置、机械旋转臂、自动覆顶组合机、自动输送电眼系统、自动上断膜装置预拉伸膜架、独立电控。

Equipment composition

Louet cantilever frame; Rotary support turning device; Mechanical rotating arm; Automatic roof covering combination machine; Automatic conveyor photo-eye system; Automatic cutting device

Equipment Introduction

The fully automatic cantilever winding and film packaging machine of Jianliang series is an integrated packaging equipment that adds the film covering to the cantilever winding packaging machine. It can complete two functions of winding packaging and top film covering, and can form a moisture-proof, rain-proof and dust-proof packaging body with five closed sides. Fully realize unmanned automatic operation, high efficiency, low packaging cost, and widely used in food and beverage, chemical fiber chemical industry, metallurgical materials and other industries, which is an excellent equipment to improve the degree of automation.

主要技术参数 TECHNICAL SPECIFICATIONS

包装尺寸	(500-1200)mmx(500-1200)mmx2200mm(LxWxH)
悬臂速度	0-20RPM可调
包装效率	≥25托/H
膜架系统	电动预拉伸膜，拉伸比可达250%，速度变频可调。
自动上断膜装置	自动夹紧、切断薄膜：无任何拖尾，完全无人自动完成。
顶膜	PE/PVC薄膜：宽度1800mm,直径100-300m,厚度30-100mm.
缠绕膜	LLDPE拉伸膜，宽度500mm;厚度20-35mm
升降部件	链条导轨升降机构，升降速度变频可调。
输送系统	输送线高度：400mm,速度：8-15mm,承重：200KG
控机系统	PLC控制，参数可调，覆膜长度可调，自动感测货物尺寸。
电机功率	悬臂1.1KW;膜架0.37KW;提升部件0.37KW;顶部覆膜0.37KW
电源	4KVA/AC380V/50HZ,3PH/N/PE
气源	0.4-0.6MPA,350NL/min
设备尺寸	4500x2200x3500mm(LxWxH)(根据实际)



自动送架机

AUTOMATIC DELIVERY MACHINE

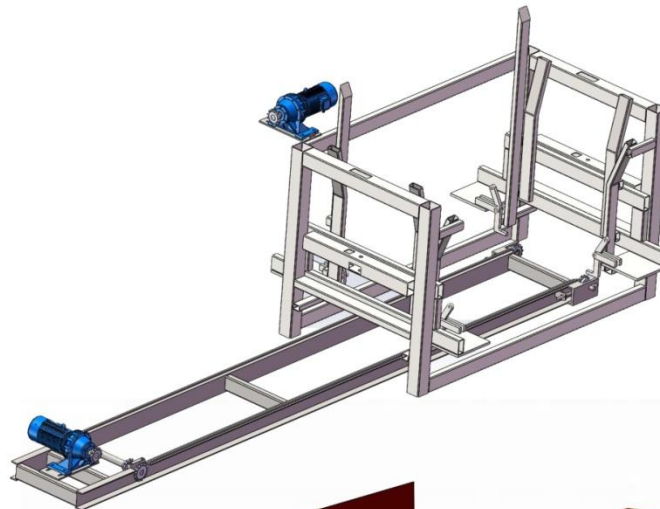

自动叠板机

AUTOMATIC PALLETIZER

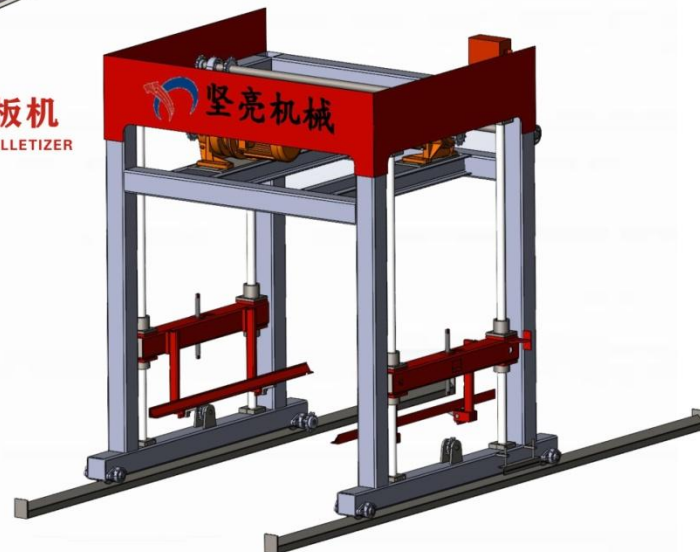

砌块砖机模具



QJ-001



QJ-002



QJ-003



QJ-004



QJ-005



QJ-006



QJ-007



QJ-008



QJ-009



QJ-010

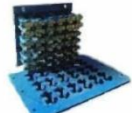

QJ-011



QJ-012



QJ-013



QJ-014



QJ-015



QJ-016



QJ-017



QJ-018



QJ-019

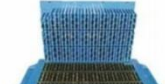

QJ-020



QJ-021



QJ-022



QJ-023



QJ-024

部分产品实样



SM-46
390X240X190



SM-47
390X240X190



SM-48
390X190X190



SM-49
390X190X190



SM-50
390X190X190



SM-51
390X190X190



SM-52
390X120X190



SM-53
390X120X190

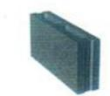

SM-54
390X90X190



SM-55
240X240X90

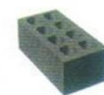

SM-61
240X115X90



SM-62
240X115X90



SM-63
190X190X190

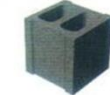

SM-64
190X190X190



SM-65
190X190X190



SM-66
390X240X90



SM-67
180X115X90



SM-68
240X115X53



SM-69
240X200X140



SM-70
240X115X90



砖的应用

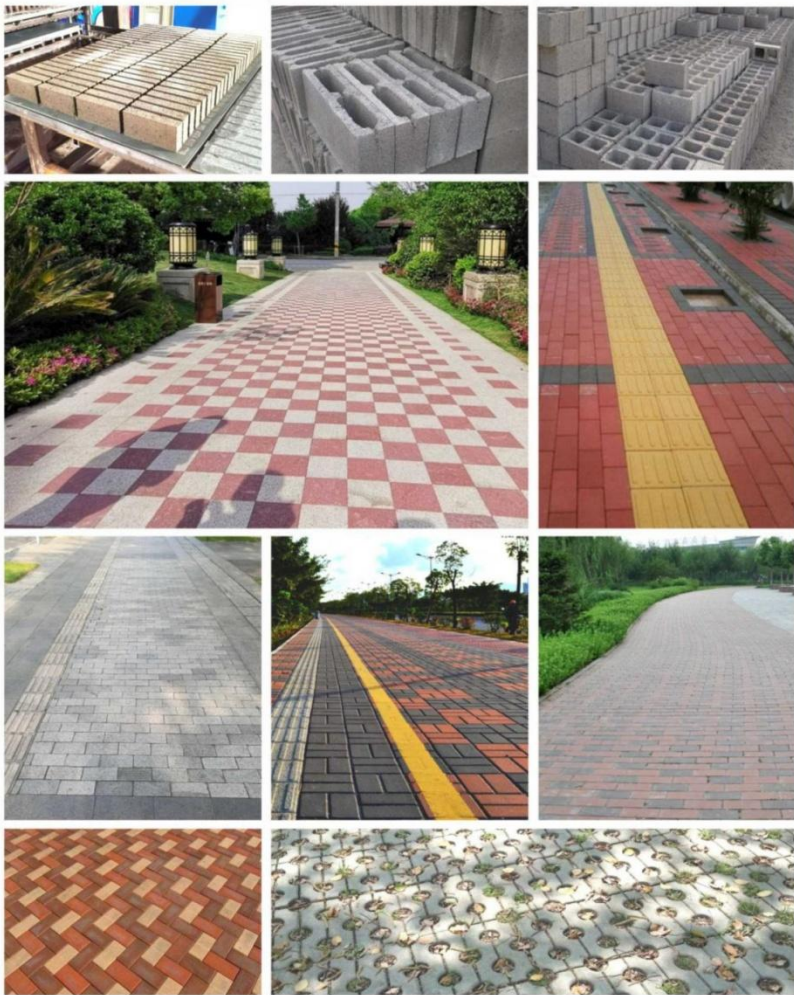

客户工厂案例



专业专注
精益求精



全自动砌块生产流程图

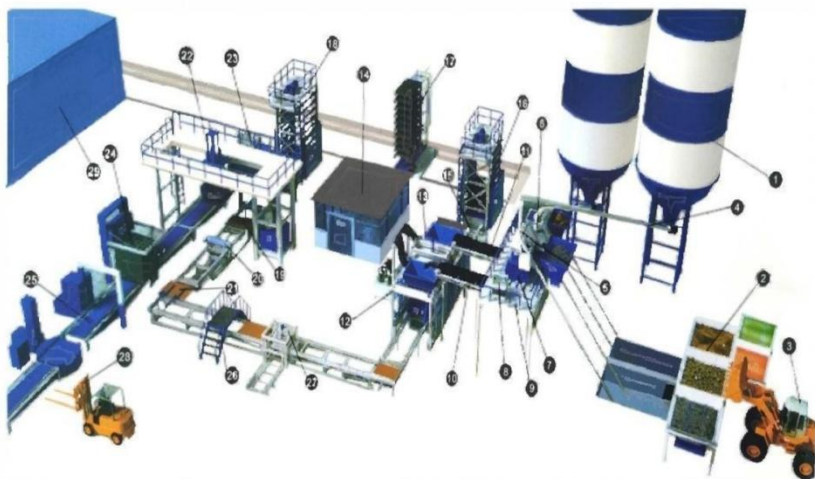

① 水泥粉罐Cement Tank	⑩ 升降梯Elevator
② 配料机Batching Machine	⑪ 子母机Finger Cart
③ 装载机Loader	⑫ 升降板机Lowerator
④ 螺旋输送机Screw Conveyor	⑬ 升降板输送机Unelevator Conveying Belt
⑤ 计量系统Measurement System	⑭ 托板清扫机Paller Cleaner
⑥ 面料搅拌机Pigment Mixer	⑮ 翻板机Pallet Tumbler
⑦ 底料搅拌机Based Material Mixer	⑯ 码垛机Cuber
⑧ 电脑控制柜Computer Control Cabinet	⑰ 托盘仓Tray Bin
⑨ 搅拌平台Mixing Platform	⑱ 打包机Strapping Machine
⑩ 底料皮带输送机Belt Conveyor For Based Materials	⑲ 成品输送带Finished Products Conveying Belt
⑪ 面料皮带输送机Belt Conveyor For Pigment	⑳ 人行天桥Pedestrian Bridge
⑫ 砌块成型机Blockforming machine	㉑ 储板装置Pallets Storage Device
⑬ 面料机pigment Mixer	㉒ 转运叉车Transmitting Forklift
⑭ 电气控制系统Electric Control System	㉓ 养护窑Curing Kiln
⑮ 接砖机Forward Block Loader	

坚亮服务

售前服务 Pre-sales Service

1. 介绍公司概况、产品技术；
 2. 为客户提供施工技术咨询并进行分析讲解疑难；
 3. 根据需求，引导客户对产品的选择。
1. Introduce the company, products and technology;
 2. Provide, analyze and explain consultation on construction technology;
 3. Suggest the best products of customers according to their demands

售中服务 On-sales Service

1. 跟踪合同，负责组织各部门对合同进行评审；
 2. 合同不明或需双方协商的问题，负责给予解决；
 3. 根据合同要求，跟踪生产及发货，以及跟踪各外协件的生产情况。
1. Follow up the contracts and organize the relevant departments to review the contracts;
 2. Solve the problems in case of any uncleanly prescribed terms or items that require mutual negotiation;
 3. Follow up the production and delivery and the production progress of outsourcing parts according to the contracts.

售后服务 After-sales Service

坚亮机械在全国设立了办事处并且建立了一支高素质的技术服务团队，实现了快速反应、客户回访、技术咨询、员工培训、长期提供配件供应、保证超值服务，为客户提供全天候的无忧服务。

Jianliang Machinery has set up offices nationwide and established a high-quality technical service team, achieving rapid response, customer follow-up, technical consultation, training, long-term provision of spare parts supply, ensuring high-value services, and providing customers with round-the-clock worry-free services.



坚亮服务热线：
139 2892 7581